

Part No.	55-610-0	Diff No. 002
5 mm	Infrared	Type : LED Lamps

Package Dimension :

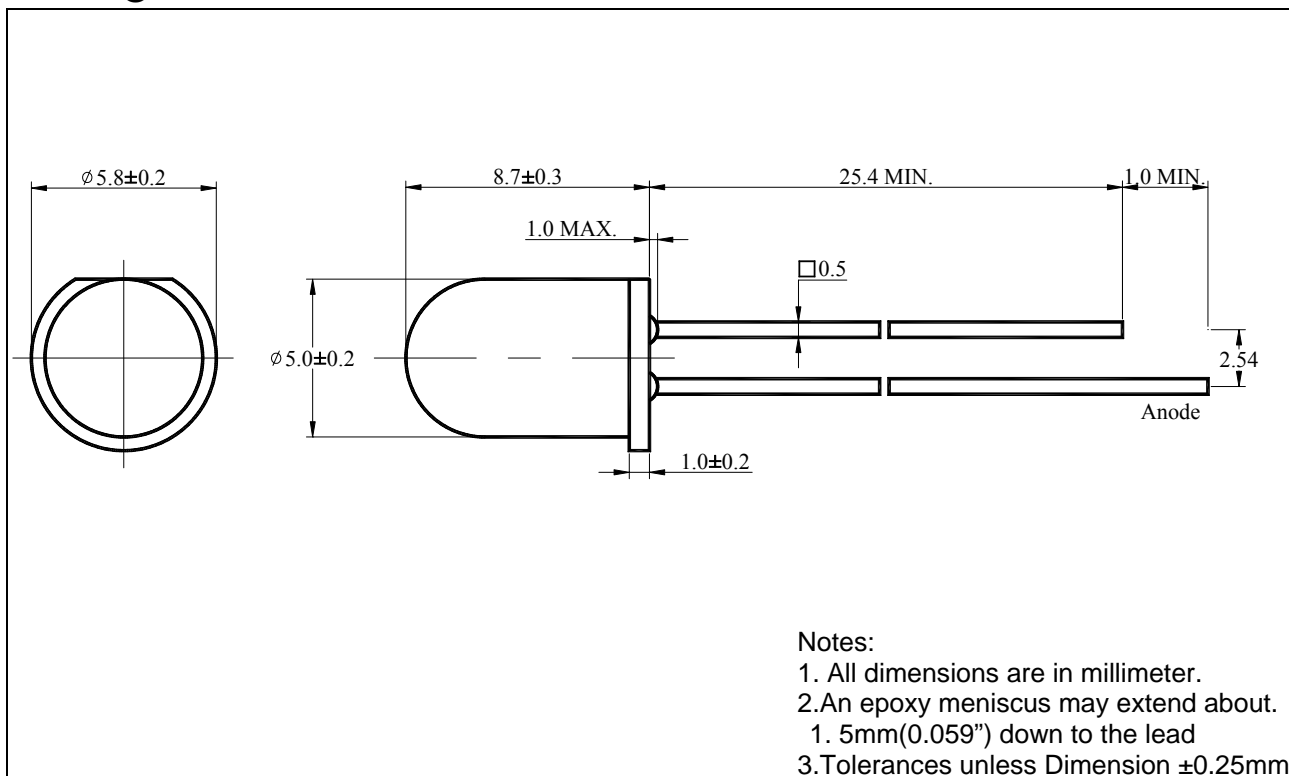

■ Features :

- Choice of various viewing angle.
- Available on Tape and Reel.
- Reliable and robust.

■ Descriptions :

- The series is specially designed for application requiring higher brightness.
- The LED lamps are available with different colors, intensity, epoxy colors etc.

■ Applications :

- TV set
- Monitor
- Telephone

Mode Electronics Ltd.

Part No.	55-610-0	Diff No. 002
5 mm	Infrared	Type : LED Lamps

PART NO.	Chip		Lens Color
	Material	Emitted Color	
55-610-0	GaAlAs	Infrared	Water Clear

■ Absolute Maximum Ratings at Ta=25°C

Parameter	Symbol	Rating	Unit
Forward Current	I _F	50	mA
Only for single LED used, but please keep the PCB temperature bellow 50°C when multi LED used.			
Operating Temperature	Topr	-40 to +85	°C
Storage Temperature	Tstg	-40 to +85	°C
Soldering Temperature	Tsol	260 ± 5	°C
Electrostatic Discharge	ESD	1000	V
Power Dissipation	P _D	180	mW
Peak Forward Current (Duty 1/10@1KHz)	I _F (Peak)	1.2	A
Reverse Voltage	V _R	5	V

■ Electronic Optical Characteristics :

Parameter	Symbol	Min.	Typ.	Max.	Unit	Condition
Radiated Output Power	P _O	20	30	/	mW/sr	I _F =50mA
Viewing Angle	2θ _{1/2}	/	30	/	deg	I _F =50mA
Peak Wavelength	λ _p	/	940	/	nm	I _F =50mA
Spectrum Radiation Bandwidth	Δλ	/	50	/	nm	I _F =50mA
Forward Voltage	V _F	/	1.3	1.45	V	I _F =50mA
Reverse Current	I _R	/	/	50	μA	V _R =5V

Mode Electronics Ltd.

Part No.

55-610-0

Diff No. 002

5 mm

Infrared

Type : LED Lamps

■ Reliability test items and conditions :

NO	Item	Test Conditions	Test Hours/Cycle	Sample Size	Ac/Re
1	Solder Heat	TEMP : 260°C ± 5°C	5 SEC	76 PCS	0/1
2	Temperature Cycle	H : +85°C 30min ┆ 5min L : -55°C 30min	50 CYCLES	76 PCS	0/1
3	Thermal Shock	H : +100°C 5min ┆ 10set L : -10°C 5min	50 CYCLES	76 PCS	0/1
4	High Temperature Storage	TEMP : 100°C	1000 HRS	76 PCS	0/1
5	Low Temperature Storage	TEMP : -55°C	1000 HRS	76 PCS	0/1
6	DC Operating Life	TEMP : 25°C I _F =20mA	1000 HRS	76 PCS	0/1
7	High Temperature / High Humidity	85°C / 85%RH	1000 HRS	76 PCS	0/1

Part No.

55-610-0

Diff No. 002

5 mm

Infrared

Type : LED Lamps

■ Typical Characteristics :

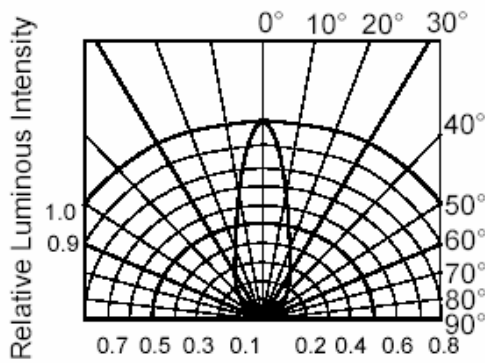

RADIATION DIAGRAM

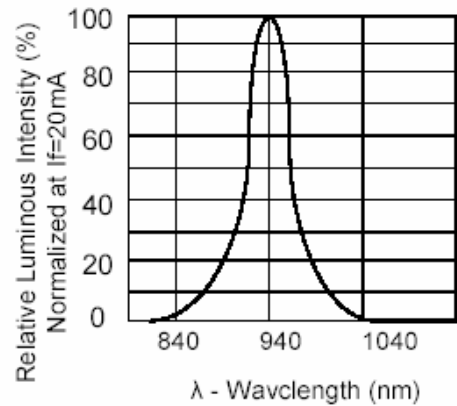

RELATIVE LUMINOUS INTENSITY Vs. WAVELENGTH

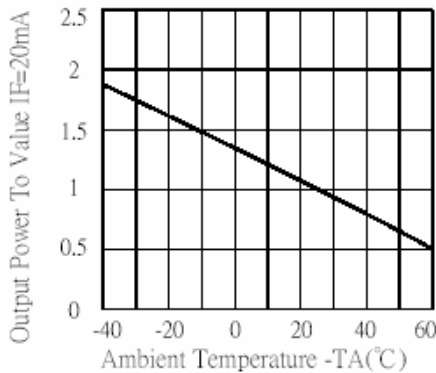

LUMINOUS INTENSITY Vs. AMBIENT TEMPERATURE

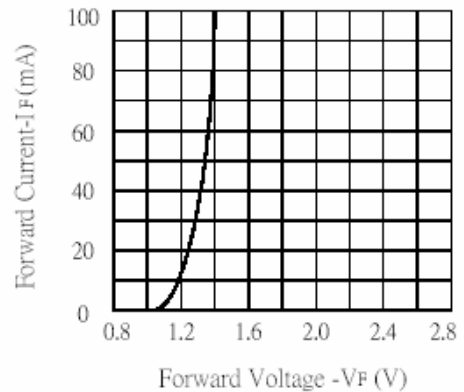

FORWARD CURRENT Vs. FORWARD VOLTAGE

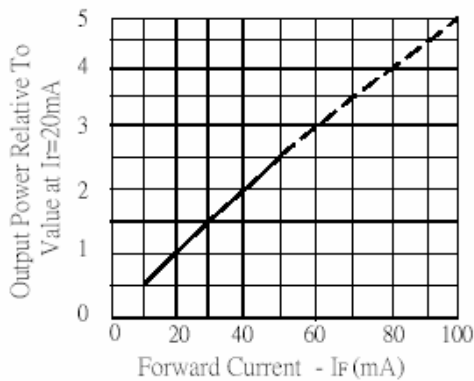

RELATIVE RADIANT INTENSITY Vs. FORWARD CURRENT