



Date: 11-15-06

FOOT SWITCHES



ALUMINUM BASE/ALUMINUM GUARD SWITCH

- Cast aluminum base and guard
- 15Amps @250VAC
- 1 N/C and 1 N/O
- Cable gland included

47-620-0

PLASTIC BASE/ALUMINUM GUARD SWITCH

- ABS plastic base - Cast aluminum guard
- 15Amps@250VAC
- 1 N/C and 1 N/O
- Cable gland included

47-621-0

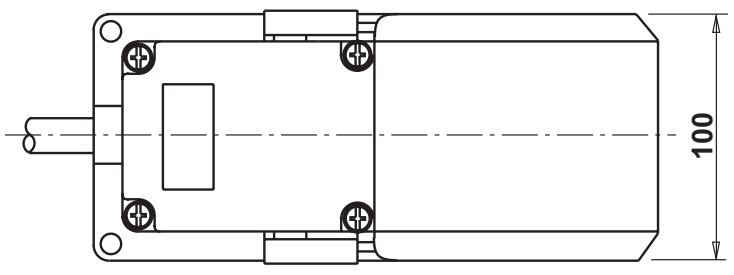
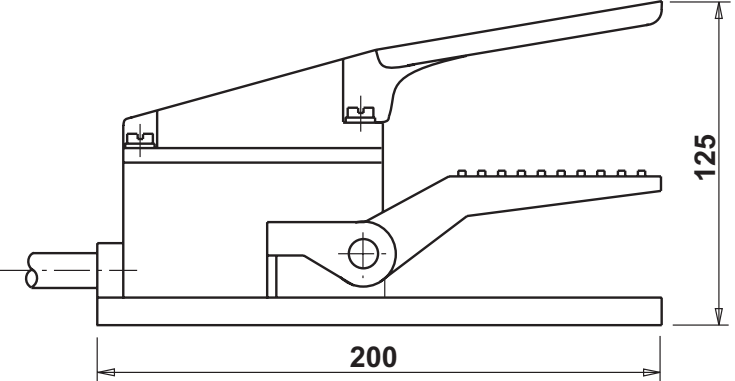

MODE ELECTRONICS LTD.

Phone: 604-435-6633 Fax: 604-435-8890 Toll Free: 1-800-663-4992

www.mode-elec.com